

DI-144 Design Idea

TOPSwitch[®]-HX

Condensing Boiler Power Supply

Application	Device	Power Output	Input Voltage	Output Voltage	Topology
Boiler	TOP258PN	50 W, 70 W Peak	185 – 265 VAC	24 V	Flyback

Design Highlights

- High efficiency under all load conditions (see Figure 2)
- High ambient temperature operation (65° C)
- >3.2 mm creepage/clearance with P package, reliable in high humidity and pollution environments
- Integrated safety/reliability features:
 - Output OVP protection configurable for latching or self recovering
 - Accurate, auto-recovering, hysteretic thermal shutdown function maintains safe PCB temperatures under all conditions
 - Auto-restart protects against output short circuits and open feedback loops
- Meets EN55022 and CISPR-22 Class B conducted EMI limits

Operation

The isolated flyback power supply shown in Figure 1 utilizes a TOP258PN. The high efficiency of this design allows for operation at a high ambient temperature (65° C) without the need for any external heatsinking.

Fuse F1 protects against catastrophic short circuit failures. Differential EMI filtering is implemented with X-capacitor C1, while

common mode EMI filtering is accomplished by common-mode choke L1 and safety rated Y-capacitor C8. AC line voltage is full-bridge rectified by diodes D8 through D11 and filtered by bulk capacitor C29. A metal film type capacitor, C4, which is located physically close to the switching circuitry, helps to decouple high frequency noise from the DC bus and improve differential EMI.

An RCD clamp is formed by D2, R17 and C34, which prevents drain voltage spikes from damaging the integrated MOSFET in U4. Zener diode VR1 is in place to assure the maximum clamp voltage and does not conduct under normal operating conditions.

A bias winding on transformer T1, which is rectified by D13 and filtered by C13, powers the TOPSwitch and provides the control current used by phototransistor U2B.

The output voltage is rectified by ultrafast diode D14, while the parallel combination of low ESR capacitors C30 and C31 provide output filtering. Inductor L2 and C32 form a second stage filter, which helps reduce output voltage ripple.

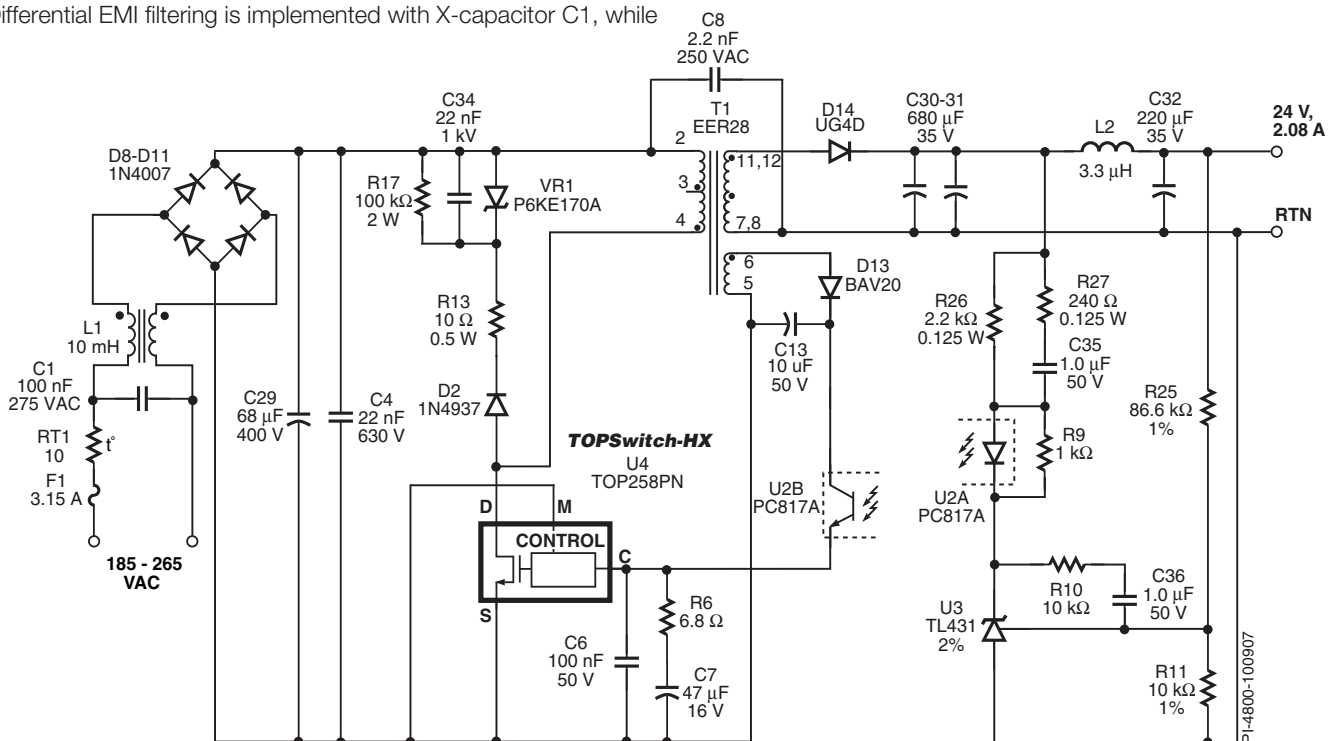

Figure 1. 50 W Continuous, 70 W Peak Condensing Boiler Supply, Designed Around a TOP258PN Device

Feedback is provided from the output via photodiode U2A, whose bias point is set through the TL431 programmable shunt regulator U3. Resistors R25 and R11 form a voltage divider network that sets the output voltage to 24 V. Resistor R10 and capacitor C36 provide compensation for the feedback network. Resistor R27 and capacitor C35 form a phase boost network that helps to improve the phase margin of the system. Resistor R9 provides a bias current to the shunt regulator, U3, while the photodiode, U2A, is not conducting. Resistor R26 sets the overall loop gain as well as limiting the current through U2A during transients.

Key Design Points

- RCD clamp components may be sized for normal operation as Zener diode VR1 will assure a safe clamping voltage during start-up and load transients.
- The current limit was programmed to a lower value using resistor R28 to approximately 50% of the internal current limit. This allows a larger TOPSwitch-HX part to be used in the application, increasing efficiency.
- The core size and the winding wire diameter sizes (see Table 1) were chosen based on the average of the peak and the continuous output power.
- The number of turns in the primary and secondary windings and the primary inductance values (see Table 1) were chosen based on the peak output power.
- Resistor R13 is used to dampen the high frequency resonant ringing while diode D2 is still conducting, thereby improving EMI.

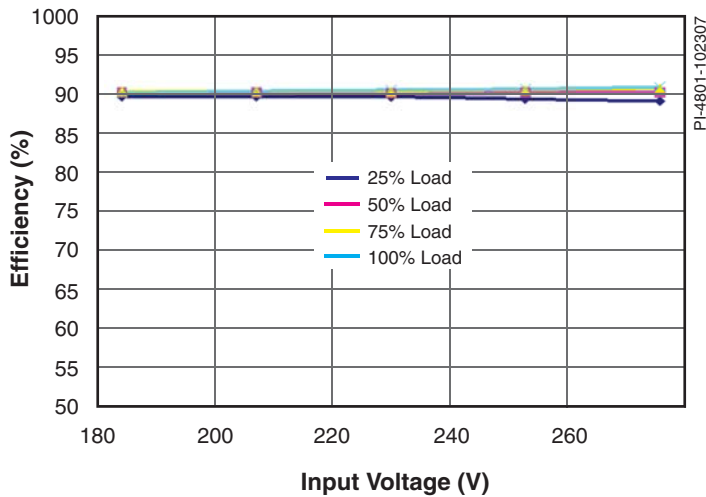

Figure 2. Efficiency Versus Load, at Standard Line Voltages

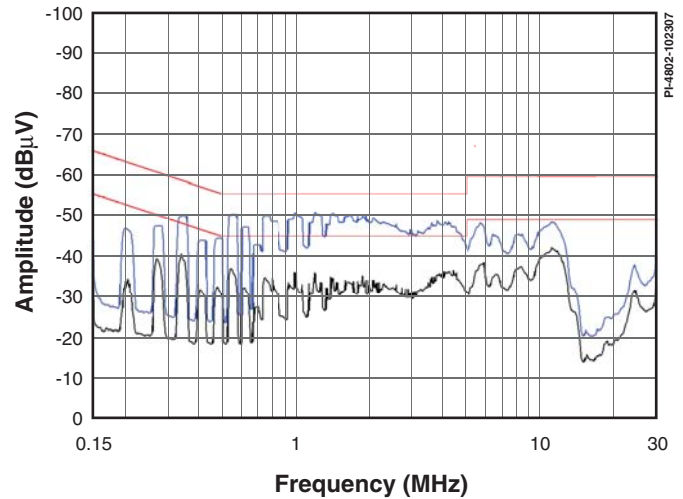

Figure 3. Worst Case Conducted EMI (230 VAC) Output Floating

Transformer Parameters

Core Material	EER28 NC-2H or equivalent, gapped for ALG of 190 nH/t ²
Bobbin	EER28, 12 pin
Winding Details	½ Primary: 38T, 27 AWG, 1 layers tape Secondary: 14T X2, 25 AWG TIW, 3 layers tape Bias: 9T x1, 25 AWG, 3 layers tape ½ Primary: 39T, 27 AWG, 3 layers tape
Winding Order	½ Primary (4–3) Secondary (11,12–7,8) Bias (6–5) ½ Primary (3–2)
Primary Inductance	1240 µH, ±10%
Primary Resonant Frequency	600 kHz (minimum)
Leakage Inductance	31 µH (maximum)

Table 1. Transformer Parameters. (NC = No Connection, TIW = Triple Insulated Wire)

Power Integrations
5245 Hellyer Avenue
San Jose, CA 95138, USA.
Main: +1 408-414-9200
Customer Service
Phone: +1-408-414-9665
Fax: +1-408-414-9765
Email: usasales@powerint.com

On the Web
www.powerint.com

Power Integrations reserves the right to make changes to its products at any time to improve reliability or manufacturability. Power Integrations does not assume any liability arising from the use of any device or circuit described herein. POWER INTEGRATIONS MAKES NO WARRANTY HEREIN AND SPECIFICALLY DISCLAIMS ALL WARRANTIES INCLUDING, WITHOUT LIMITATION, THE IMPLIED WARRANTIES OF MERCHANTABILITY, FITNESS FOR A PARTICULAR PURPOSE, AND NON-INFRINGEMENT OF THIRD PARTY RIGHTS. The products and applications illustrated herein (transformer construction and circuits external to the products) may be covered by one or more U.S. and foreign patents or potentially by pending U.S. and foreign patent applications assigned to Power Integrations. A complete list of Power Integrations' patents may be found at www.powerint.com. Power Integrations grants its customers a license under certain patent rights as set forth at <http://www.powerint.com/ip.htm>.

The PI logo, TOPSwitch, TinySwitch, LinkSwitch, DPA-Switch, PeakSwitch, EcoSmart, Clampless, E-Shield, Filterfuse, StackFET, PI Expert and PI FACTS are trademarks of Power Integrations, Inc. Other trademarks are property of their respective companies. ©2007, Power Integrations, Inc.